

JTMB8536

0.9V startup, 1MHz, 300mA Iout, Low Iq, Synchronous Boost converter

DESCRIPTION

The JTMB8536 is a step-up converter that provides a boosted output voltage from a low voltage source. Because of its proprietary design, it starts up at a very low input voltage down to 0.9V, and only consumes 15uA at standby, making it an ideal choice for single cell alkaline/NiMH battery operations.

A switching frequency of 1MHz minimizes solution footprint by allowing the use of tiny, low profile inductors and ceramic capacitors. The current mode PWM design is internally compensated, reducing external parts count.

JTMB8536 is available in SOT23-3 and SOT89-3 Package.

FEATURES

- Efficiency up to 94%@Vin=3.3V, Vout=5.5V
- Typical 15uA standby current
- 1MHz Switching Frequency allows small inductor and output cap
- Input boost-strapping allows using small or no input cap
- Low Vin Start-up Voltage down to 0.9V Ideal for Single Alkaline Cell operations
- Maximum Output Current up to 300mA
- Low Noise PWM control
- Internally Compensated Current Mode Control
- Internal Synchronous Rectifier
- Available in SOT23-3 and SOT89-3

APPLICATIONS

- One to Three Cell Battery Operated Devices
- Medical Instruments
- Bluetooth Headsets
- Flash-Based MP3 Players
- Noise Canceling Headphones

TYPICAL APPLICATION

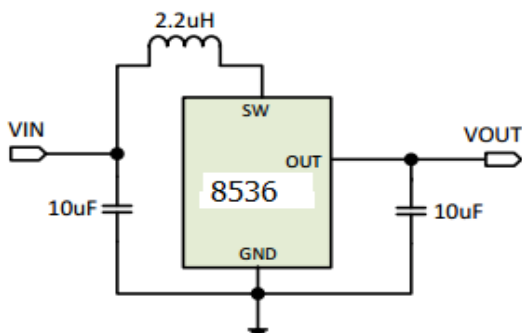

PIN OUT & MARKING

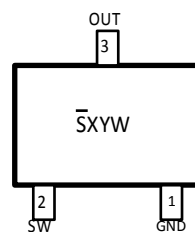

SOT23-3

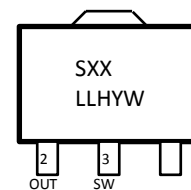

SOT89-3

S: Product Code
X: Output Voltage
YW: Date code

S: Product Code
XX: Output Voltage
LL: LOT No.
H: FAB Code
YW: Date code

ORDERING INFORMATION

PART No.	PACKAGE	Tape&Reel
JTMB8536CB3TR	SOT23-3	3000/Reel
JTMB8536CC3TR	SOT89-3	1000/Reel

ABSOLUTE MAXIMUM RATING

Parameter	Value	
SW Voltage	-0.3 ~ 6V	
OUT Voltage	-0.3 ~ 6V	
Max Operating Junction Temperature(Tj)	125°C	
Maximum Power Dissipation	SOT23-3	450mW
	SOT89-3	500mW
Ambient Temperature(Ta)	-40°C – 85°C	
Storage Temperature(Ts)	-55°C - 150°C	
Lead Temperature & Time	260°C, 10S	

Note: Exceed these limits to damage to the device.

Exposure to absolute maximum rating conditions may affect device reliability.

ELECTRICAL CHARACTERISTICS

(TA=25°C)

Symbol	Parameter	Conditions	Min	Typ	Max	Unit
Vin	Input Voltage Range		0.9		5	V
Vstart	Startup Voltage	Iout = 1mA		0.9		V
Vhold	Hold Voltage	Iout = 50mA		0.5	0.7	V
Vout	Output Voltage Range		1.8		5.5	V
	Output voltage accuracy	Iout = 0mA		2		%
	Line regulation	Iout = 50mA		0.1	0.2	%/V
	Load regulation	Iout = 0~300mA		1	2	%
Fsoc	Switching Frequency	Vout=0.95Vo, No inductor	0.7	1	1.4	MHz
	Max Duty cycle	Vout=0.95Vo, No inductor	85	90	95	%
Iq	Quiescent Current at Vout	Vout=1.05*Vo	5	8	15	uA
	Supply current at Vin	Iout = 0mA			20	uA
	Efficiency	Iout = 100mA	85			%
RdsonP	PMOS Rdson	Isw =100mA		400	600	mohm
RdsonN	NMOS Rdson	Isw =100mA		200	300	mohm
Iswlk	SW Leakage Current	Vout=5.2V, Vsw=0 or 5.2V			1	uA

PIN DESCRIPTION

PIN #		NAME	DESCRIPTION
SOT23-3	SOT89-3		
3	2	OUT	Output voltage pin, with 10uF ceramic capacitor closely connected to GND
1	1	GND	Ground
2	3	SW	To connect inductor to VIN

BLOCK DIAGRAM

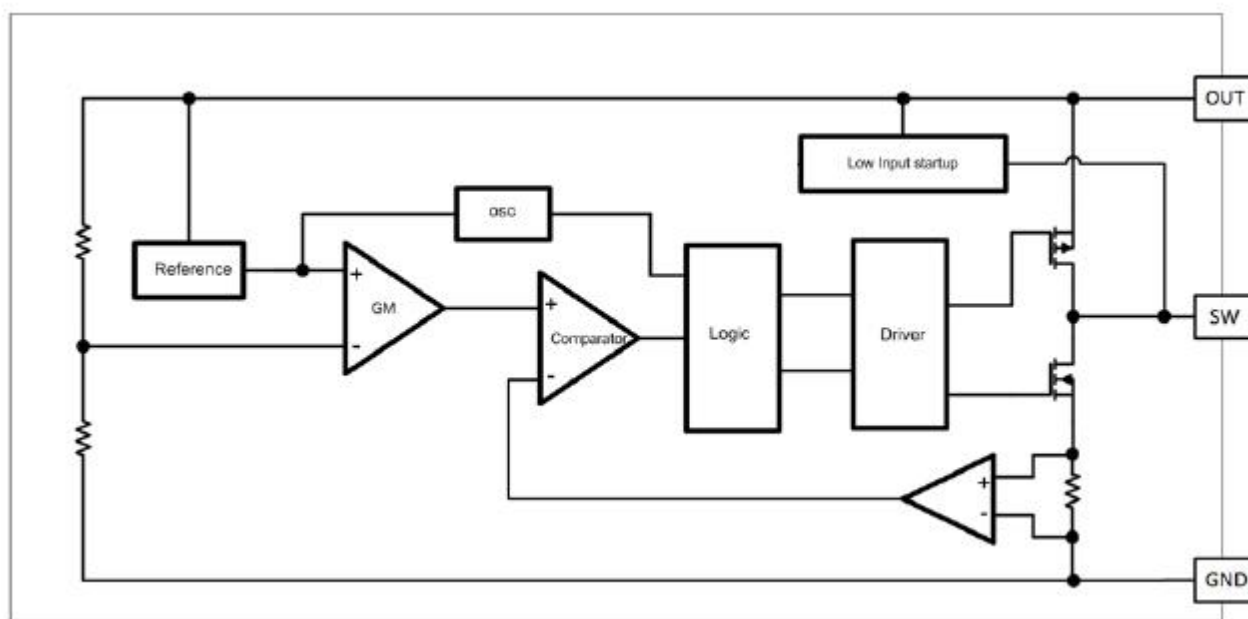

ELECTRICAL PERFORMANCE

Tested under $C_{in}=C_{out}=10\mu F$, $L=2.2\mu H$, $T_A=25^\circ C$, unless otherwise specified

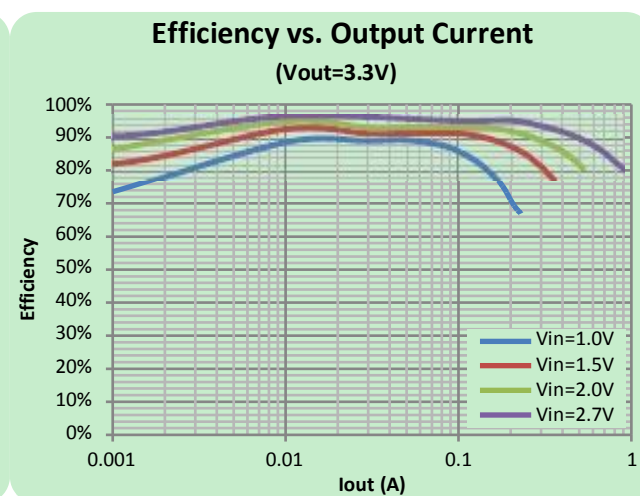
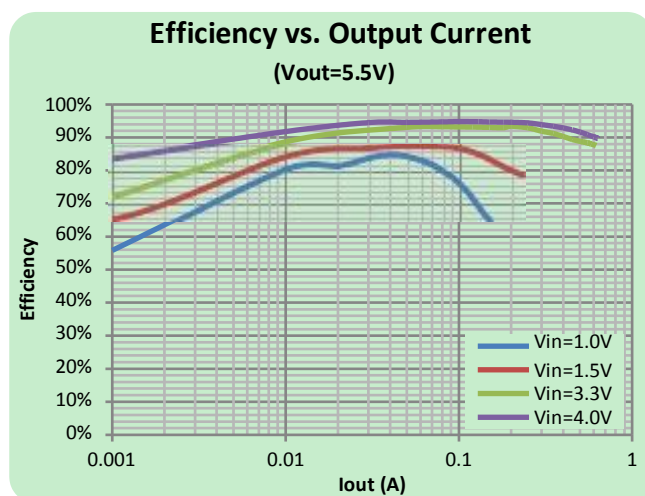

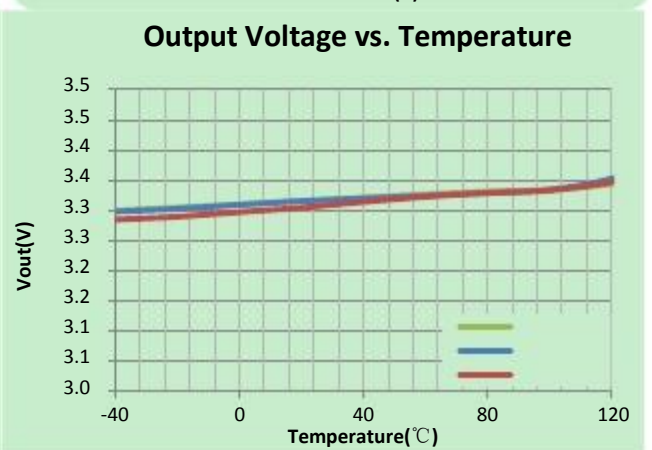
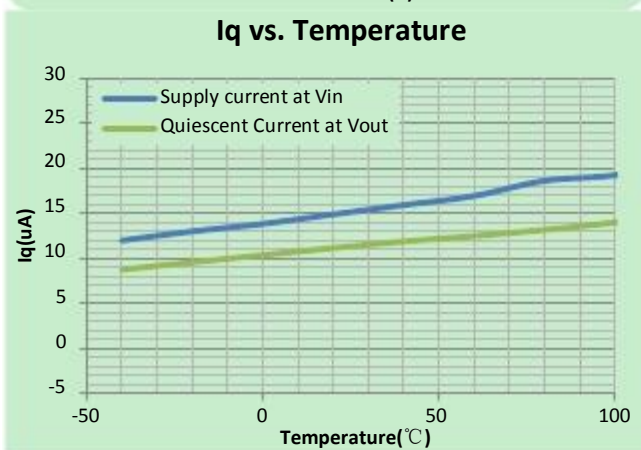
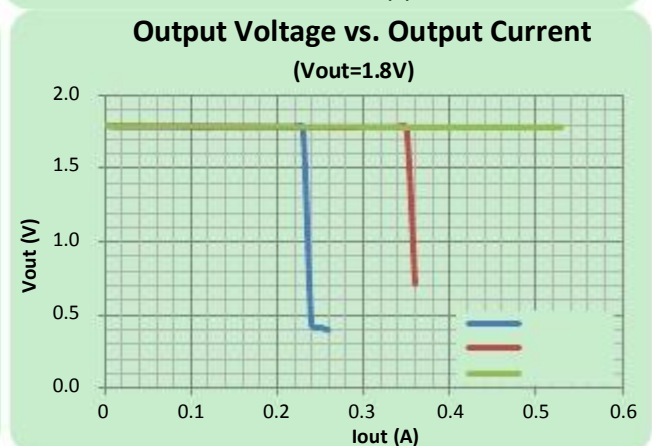
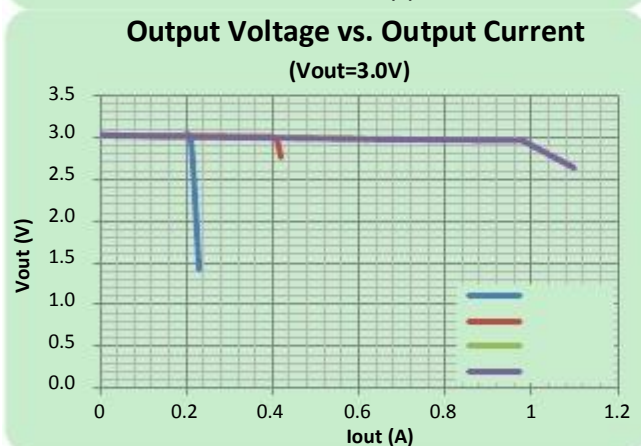
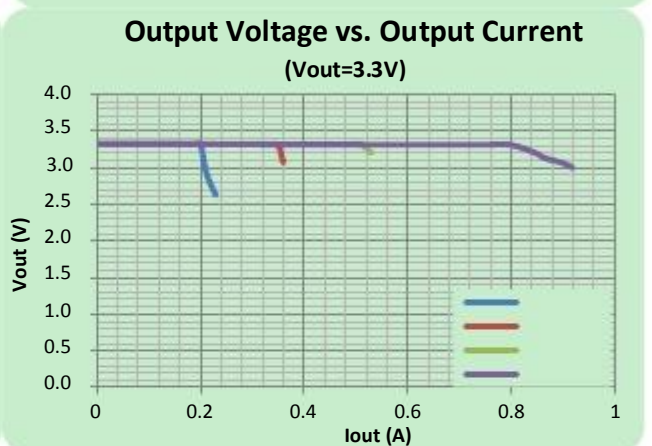
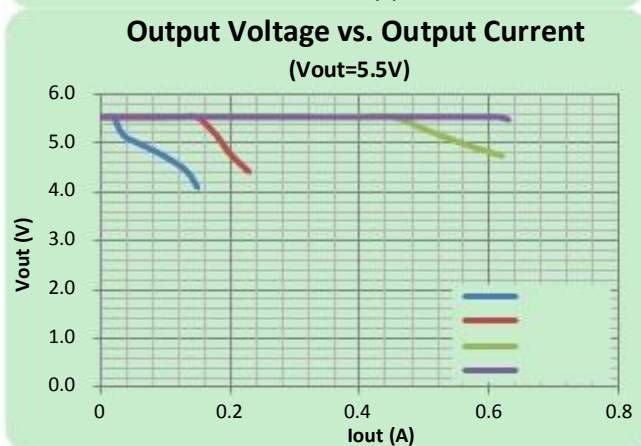
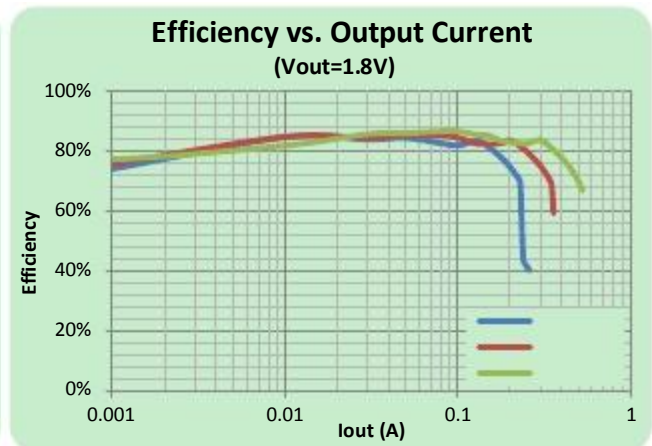
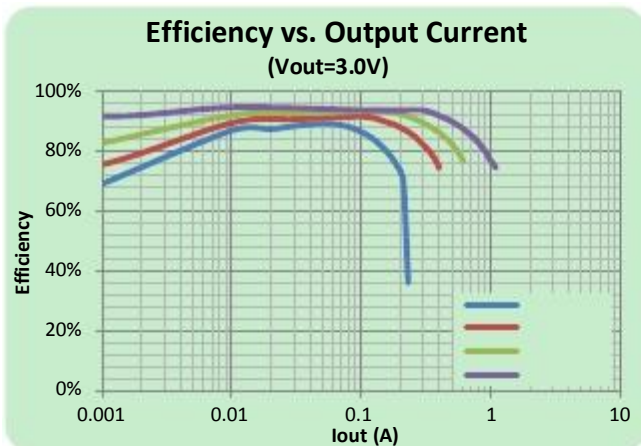

DETAILED DESCRIPTION

JTMB8536 is a low input voltage start up, current mode DC-DC step up converter. It's operation can be best understood by referring to the block diagram. Upon starting up, the low voltage startup circuitry drives SW with on-off cycles, transferring energy from input to OUT by storing energy in the inductor during on-time and releasing it to the output during off-time. When OUT reaches 2V, the startup circuit turns off and the main controller takes over. The main control loop consists of a reference, a GM error amplifier, a PWM controller, a current sense amplifier, an oscillator, a PWM logic control, and it is power stage including its driver. The main control loop is a classic current mode control loop. The GM stage integrates the error between FB and REF, and its output is used to compare with a triangular wave which the summing result of the current sense amplifier output and a slope compensation voltage. The output of the comparator is used to drive the power stage to reach regulation.

APPLICATION INFORMATION

Inductor selection

With switching frequency up to 1MHz, small surface mount inductors can be used with values from 2.2uH to 4.7uH. For a given chosen inductor value and application conditions make sure the peak inductor current does not exceed the maximum current rating of the selected vendor's inductor.

Input and output capacitor selection

The JTMB8536's bootstrap architecture allows the use of very small input capacitor. For applications that only need to drive small output load current, the input capacitor is optional, because once output is started up, the IC's is powered by OUT, a quiet power supply.

The output capacitor is used to stabilize the loop and provide ac current to the load. A low ESR ceramic cap with values from 2.2uF to 22uF can be used. Smaller value capacitors are generally cheaper with small footprints, while larger capacitor provides lower ripples and better transient load responses. Also, when extreme low startup voltage is needed, larger output capacitors are needed for the part to startup under heavy load condition.

PACKAGE OUTLINE

Package	SOT-23-3	Devices per reel	3000Pcs	Unit	mm
Package dimension:					
<p>Technical drawing of the SOT-23-3 package. The top view shows a width of 2.9 ± 0.2 mm and a length of 1.9 ± 0.2 mm. The distance between the two leads is 1.9 ± 0.2 mm, with each lead offset by 0.95 mm from the center. Lead 1 is 0.4 ± 0.1 mm wide and 1.6 ± 0.2 mm long. Lead 2 is 0.4 ± 0.1 mm wide and 1.6 ± 0.2 mm long. The total length of the package is 2.8 ± 0.3 mm. The side view shows a maximum height of 1.4 mm, a lead height of 1.1 mm (tolerance $+0.2$, -0.1), a lead thickness of 0.8 mm, and a lead width of 0.2 mm (minimum). The bottom view shows a lead width of 0.16 mm (tolerance $+0.1$, -0.06) and a lead thickness of 0.2 mm (minimum).</p>					

Package	SOT-89-3	Devices per reel	1000Pcs	Unit	mm
Package dimension:					
<p>Technical drawing of the SOT-89-3 package. The top view shows a width of 4.5 ± 0.1 mm and a length of 1.6 ± 0.2 mm. The distance between the two leads is 1.6 ± 0.2 mm. Lead 1 is 0.4 mm wide and 2.5 ± 0.1 mm long. Lead 2 is 0.4 mm wide and 2.5 ± 0.1 mm long. The total length of the package is 4.25 mm (maximum). The side view shows a maximum height of 1.5 ± 0.1 mm, a lead height of 0.4 ± 0.1 mm, a lead thickness of 0.4 ± 0.1 mm, and a lead width of 0.4 ± 0.1 mm. The bottom view shows a lead width of 0.42 ± 0.2 mm, a lead length of 1.5 ± 0.1 mm, and a lead thickness of 0.47 ± 0.1 mm.</p>					